

# AMERICAN POWER HOIST

## INSTALLATION GUIDE

All installations should be done by a qualified professional installer. The installer is responsible for confirming the structure is suitable for lifting a boat. The installer agrees to instruct the owner/lift operator on safe operation, maintenance, and servicing the lift system.

**This is a General Guide to assist when installing a lift. Boat house applications vary by design and construction.**

The gear drive plate can be mounted horizontally or vertically. If using the PSI/APH Drive, it must mount vertical only-mounting bolts on top. When mounting, drive unit must be positioned 90 degrees with the drive pipe; see illustration. Sometimes washer/shims may be necessary to achieve this angle. Do not mount on warped or bowed wood boards.

Before installing drive pipe check to make sure it is straight. Pipe can be checked by simply rolling it on the edge of 2X4" board. Pipe must be straight to insure proper performance of the lift and use a pipe without jointed sleeve. Pipe support hangers must be mounted straight and level with the drive pipe. The drive pipe must turn freely with no binding- **DO THIS BEFORE INSTALLING** cable. (If using the 'V' style pipe bearing, it may be necessary to add washers to eliminate any binding of drive pipe). When using 2-single support pipe bearings, never exceed 24" between pipe supports.

When using the dual pipe bearing, mount brackets use bolts and nuts and necessary washers, see illustration. **DO NOT USE LAG SCREWS.**

Install pulley blocks on opposite sides of support timbers, see illustration.

When installing cables, drill hole in pipe 1/16" larger than the size of cable used. Cable must run the same direction on each end of the lift, see illustration.

Follow cable clamp instructions when installing cable clamps. Always give a minimum of 3 WRAPS of cable on pipe, before lifting boat. Inspect cable and use cable lube on a regular basis. Replace cable if broken strands, flat spot, rust detected, or any abnormal appearance.

When lowering the boat, the hoist bull gear should turn clockwise. Always mount control switch with wires leading out of the bottom of the switch, see illustration.

**NEVER STAND UNDER THE BOAT LIFT WHEN IT IS RUNNING OR IN A LIFTED POSITION WHEN STOPPED. NEVER LIFT PEOPLE OR ANIMALS IN THE BOAT WHEN RAISING OR LOWERING THE BOAT.** Stay well clear of the boat when being raised and lowered.

**NEVER OPERATE LIFT WITH AN EXTENSION CORD.** Have a qualified electrician approve electrical requirements and install electrical components.

Check and know the weight of your boat - with gas or any boating gear on the boat. Never exceed 90% of any rated capacity boat hoist.

**YOU MUST USE 2" I.D. (INSIDE DIAMETER) SCHEDULE 40 DRIVE PIPE WITH THIS KIT.**

**A.P.H**

**SEE FRONT AND BACK PAGE**

# CABLE ARRANGEMENT

## Straight Lift System

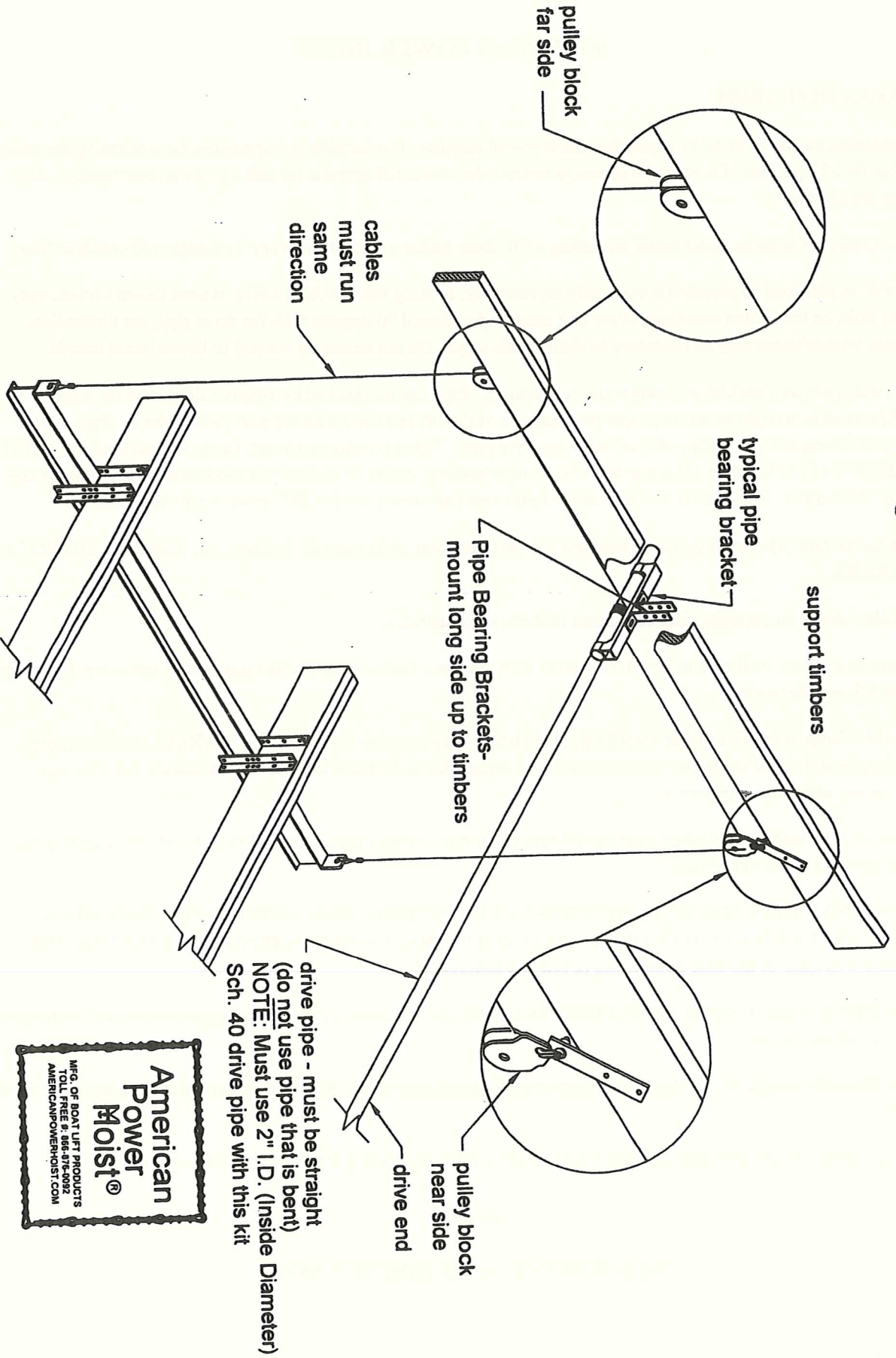

# CABLE TERMINATION-INSTALLATION GUIDE

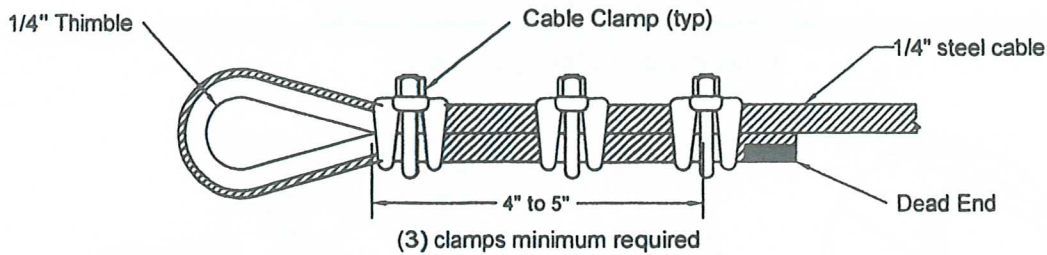

## TO APPLY CABLE CLAMPS:

Apply exactly as shown above. The "U" section is in direct contact with dead end of cable. Apply first clamp one base width from dead end. Apply second clamp as close as possible to loop. Apply third clamp between the two clamps. Apply initial load to cable system and retighten nuts to torque requirements listed below. Cable will stretch and shrink in diameter when load is applied. Inspect periodically and retighten to torque value.

## TORQUE REQUIREMENTS PER CABLE SIZE:

1/4" CABLE = 15 FT. LBS. TORQUE

5/16" CABLE = 30 FT. LBS. TORQUE

# CAUTION

Failure to terminate cable ends according to these instructions or failure to periodically check and retorquer clamp nuts will result in reduction of efficiency rating and may cause personal injury or property damage.

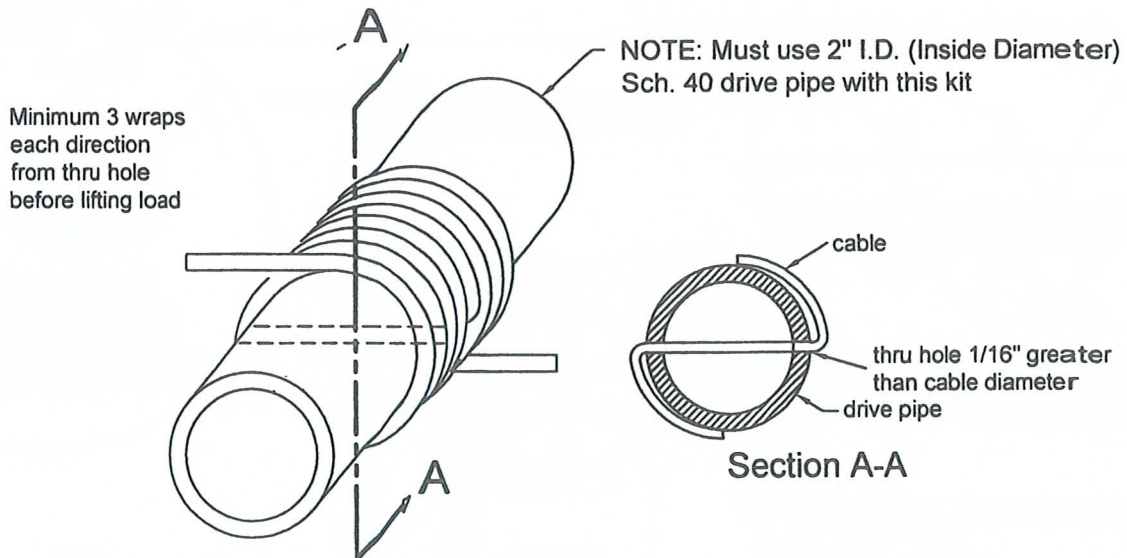

## MOTOR WIRING SIZE REQUIREMENTS (SINGLE PHASE MOTOR)

HP	VOLTAGE	MINIMUM WIRE GAGE FOR BRANCH CIRCUITS INDICATED			
		0-50 FT	100 FT	200 FT	500 FT
3/4	230	14	12	10	6
	115	12	8	6	2
1 or 1 1/2	230	14	10	8	4
	115	10	8	6	—

# CABLE ARRANGEMENT

## Compound Cable System

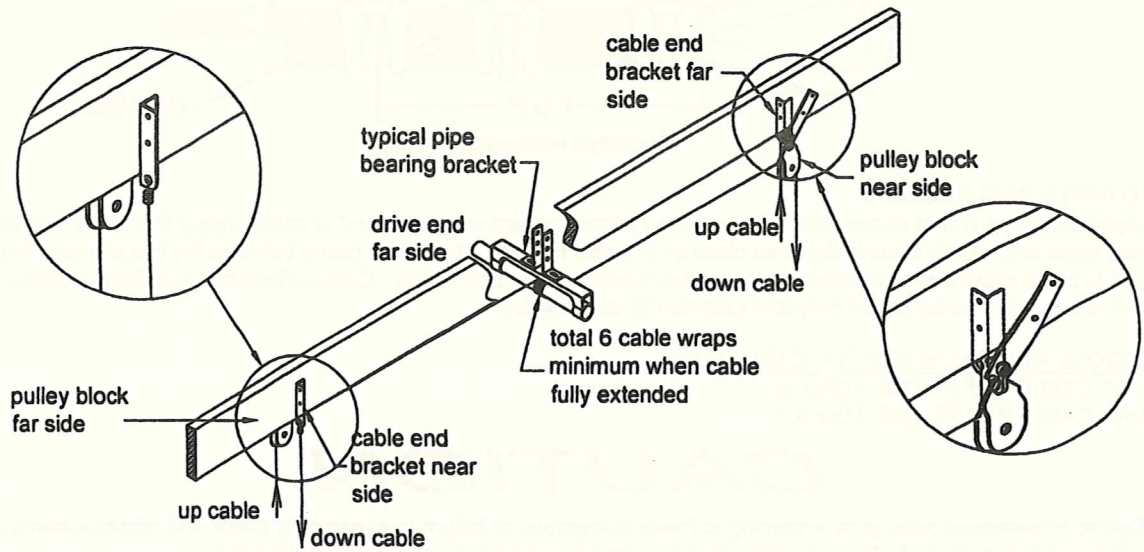

## DRIVE ORIENTATION

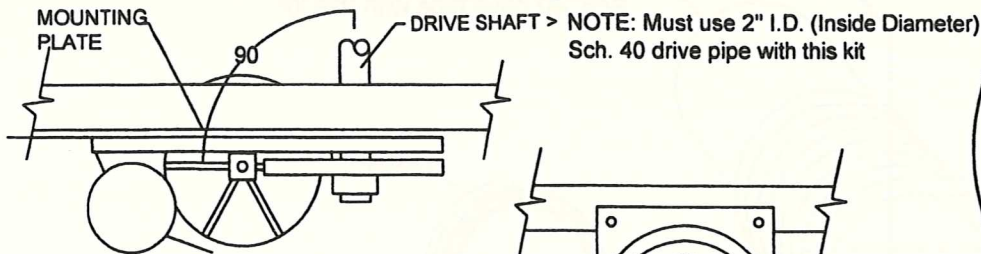

MOUNTING PLATE MUST BE 90° TO DRIVE SHAFT IN BOTH HORIZONTAL AND VERTICAL PLANES USE SHIMS AS REQUIRED

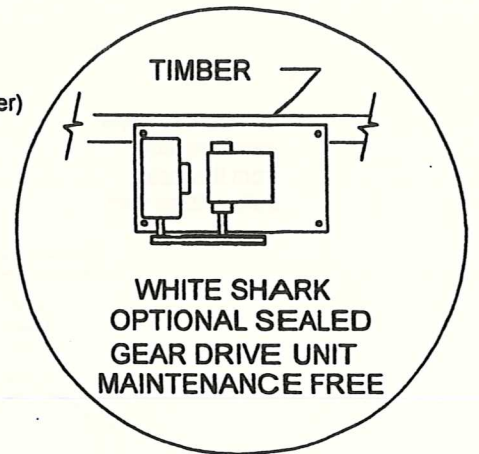

WHITE SHARK  
OPTIONAL SEALED  
GEAR DRIVE UNIT  
MAINTENANCE FREE

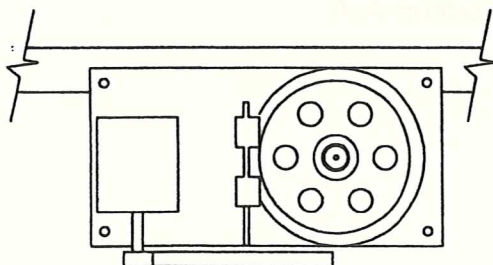

BULL GEAR MUST TURN CLOCKWISE WHEN LOWERING BOAT

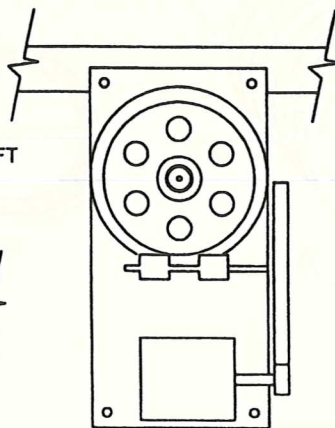

ALTERNATE  
MOUNT  
POSITION

229  
American  
Power  
Moist®

## GENERAL CABLE INFORMATION

The intention of this information is to be a general guide line of cable use to familiarize the customer with wire rope and it's characteristics. All cable (wire rope) has a **limited life** regardless of the material it is made of. **CABLE LIFE** is a variable based on use, load, maintenance, exposure and application. It is impossible to put a definite time limit on the life expectancy of such an apparatus. Keep in mind that cable is a consumable part of any lifting device. It is designed to be "used up" and replaced from time to time as an economical part of the lift.

## GALVANIZED CABLE VS. STAINLESS STEEL

The inclusion of nickel into the steel used to make a cable **CORROSION RESISTANT** is done at a sacrifice of flexibility and strength. Nickel is a more brittle material and reduces the lifting capacity of a cable of similar diameter made of galvanized strands.

## GALVANIZED CABLE

Galvanized cable is the preferred cable for applications where the cable is not submersed in water (fresh or salt). Being more flexible and stronger than stainless steel, it has properties that make it the cable of choice when application permits. It has the same **Cable Life** as stainless steel cables when properly lubricated and maintained; and can be replaced twice at about the same cost to replace stainless steel cable.

Cable in general is a working machine of individual strands that must be able to move independent of each other. This is how the cable remains it's flexibility and strength. Lubrication is key to **Cable Life**. A galvanized cable will give indication of age and need for replacement by taking on a surface rust that is visible upon examination. Inspect the cable before each use and during each operation for broken strands, deformities, and any other indication of wear or damage. The red oxidation (rust) is easily recognized by the average person as a warning to maintain or replace whatever it is that is showing corrosion.

## STAINLESS STEEL CABLE

Stainless steel cable does not show age as readily as galvanized cable. Stainless steel oxidizes black and is not as easily identified as a problem. Many times stainless steel cable will corrode from the inside, and will not give any indication to the untrained eye. As the cable corrodes from the inside, cable diameter is reduced, but it is not readily noticeable. You must inspect the cable very closely to see broken strands or wear. Measuring the diameter of the cable is the only sure way to determine diameter reduction, though few of us have the tools or knowledge on how this is to be done correctly.

## AMERICAN POWER HOIST

## GENERAL CABLE INFORMATION

## IMPORTANT INFORMATION - MAINTENANCE

**CAUTION:** AMERICAN POWER HOIST BOAT LIFTS ARE **NOT** DESIGNED TO BE USED FOR HOISTING OR TRANSFER OF PEOPLE, OR FOR HOISTING LOADS OVER PEOPLE OCCUPIED AREAS. **DO NOT** ALLOW ANY PERSON IN OR UNDER THE BOAT WHILE SUSPENDED ON LIFT.

\*DUE TO THE CONDITIONS IN WHICH THE LIFT MUST OPERATE, REGULAR MAINTENANCE AND LUBRICATION IS NECESSARY.

\*\* THE A.P.H. ELECTRIC POWER HOIST IS EQUIPPED WITH 3 GREASE FITTINGS. IT IS NECESSARY THAT ALL GREASE FITTINGS, AS WELL AS GEAR TEETH, ARE THOROUGHLY PACKED WITH GREASE TO INSURE THE MECHANISMS LONGEVITY.  
\*\*\*LIFTS ARE SUPPLIED WITH GALVANIZED OR STAINLESS STEEL CABLES. IT IS IMPORTANT THAT CABLES HAVE PERIODIC LUBRICATION TO REDUCE CHAFING OF STRANDS AND EXTEND **CABLE LIFE**. TIMELY PERIODIC INSPECTIONS OF CABLES FOR STRAND BREAKAGE ARE NECESSARY. GALVANIZED OR STAINLESS STEEL CABLES **DO NOT** HAVE AN INDEFINITE LIFE AND MUST BE REPLACED PERIODICALLY.

\*\*\*\*CHECK ALL CABLES FOR RUST AND BROKEN STRANDS. IF EXTREME NUMBER OF STRANDS ARE BROKEN, OR IF THE CABLE IS RUSTY, IT MUST BE REPLACED.

\*\*\*\*\* IF CABLE CLAMPS ARE USED, CHECK AND TIGHTEN THEM AT EACH INSPECTION.

\*\*\*\*\* CHECK AND TIGHTEN ALL NUTS AND BOLTS.

# WARNING

## ELECTROCUTION HAZARD

**Important Read this before installing lift**

Proper grounding is essential for the GFCI to function. Have the ground circuit checked by a professional electrician to prevent a lethal shock.



If Not Installed by a Licensed Electrician the factory installed Ground Fault Circuit Interruptor (GFCI) MUST not be removed or Disarmed.

Removal of factory installed GFCI may only be done by a Licensed Electrician following all Federal, State & Local codes. Federal code requires a GFCI to be within the electrical circuit. If factory GFCI is removed, the feed circuit must provide GFCI Protection.

The GFCI Provides Protection Against Certain Types of Shocks.

Test GFCI Before Each Use. See Testing Direction on Back of GFCI.